

VERTICAL MAGNETIC LIFTER

Use :

For lifting and transporting loads up to 3000kg
Manual activation for individual charging

Features :

- Powerful Neodymium magnets ensure optimal lifting capacity even on raw parts
- SAV lifting magnets are tested individually
- The safety coefficient is at least 3
- Lifting force for round parts decreases by more than 50%
- Easy activation by rotating the lever with safety system
- 180° articulated / 360° rotating lifting ring
- Compact, robust and reliable



SAV 531.01M-V



Type		100M-V	300M-V	600M-V	1000M-V	2000M-V	3000M-V
Rated lifting capacity*							
- Horizontal flat piece	kg	100	300	600	1000	2000	3000
- Horizontal round piece	kg	45	150	250	450	900	1350
- Vertical flat piece	kg	20	60	120	200	400	600
- Vertical round piece	kg	9	30	50	90	180	270
Mini. Thickness	mm	2	4	6	10	15	20
Diameter mini/maxi	mm	30 - 100	30 - 200	40 - 250	60 - 350	150 - 400	150 - 400
A	mm	130	200	250	350	450	500
B	mm	75	80	106	145	210	255
C	mm	67	90	98	120	175	195
D	mm	50	70	70	100	110	150
E	mm	40	50	50	80	90	100
∅	mm	10	12	16	20	25	40
G	mm	112	112	112	116	155	160
H	mm	38	38	38	38	53	53
I	mm	27	27	27	37	38	38
Weight	kg	4,5	10,0	19,0	43,0	114,0	193,0

*Maximum weight for S235JR steel parts with smooth contact surfaces of sufficient size and thickness. The lifting capacity varies depending on the type of material, the thickness of the part, the size and quality of the surface in contact.

Order example:

Vertical magnetic lifter
Designation

SAV 531.01 - 300M-V
SAV N° - Type

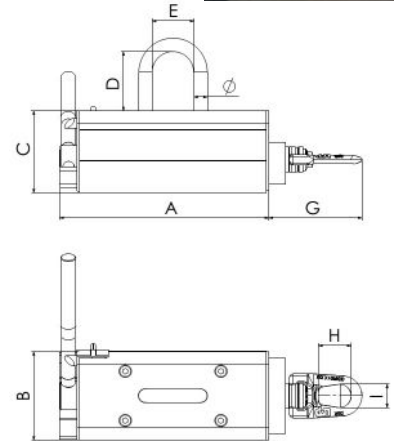

VERTICAL MAGNETIC LIFTER

Use :

For lifting and transporting loads up to 2000kg
Manual activation for individual charging

Features :

- Powerful Neodymium magnets ensure optimal lifting capacity even on raw parts
- SAV lifting magnets are tested individually
- The safety coefficient is at least 3
- Lifting force for round parts decreases by more than 50%
- Easy activation by rotating the lever with safety system
- 180° articulated / 360° rotating lifting ring
- Compact, robust and reliable



SAV 531.01SAV-V



Type		150SAV-V	300SAV-V	600SAV-V	1200SAV-V	2000SAV-V
Rated lifting capacity*						
- Horizontal flat piece	kg	150	300	600	1200	2000
- Horizontal round piece	kg	65	150	300	600	1000
- Vertical flat piece	kg	30	60	120	240	400
- Vertical round piece	kg	13	30	60	120	200
Mini. Thickness	mm	2	4	6	10	15
Diameter mini/maxi	mm	40 - 100	60 - 200	65 - 270	100 - 300	150 - 350
A	mm	93	152	246	305	480
B	mm	60	100	120	140	165
C	mm	69	100	100	125	161
D	mm	40	60	65	90	90
E	mm	30	50	50	64	64
F	mm	235	300	395	460	680
G	mm	117	117	117	125	165
H	mm	38	38	38	38	53
I	mm	27	27	27	27	38
∅ lifting ring	mm	10	16	16	20	20
Weight	kg	3,5	11,0	21,0	41,5	92,0

*Maximum weight for S235JR steel parts with smooth contact surfaces of sufficient size and thickness. The lifting capacity varies depending on the type of material, the thickness of the part, the size and quality of the surface in contact.

Order example:

Vertical magnetic lifter
Designation

SAV 531.01- 600SAV-V
SAV N° - Type

